



HOH-trgovina
Dogoška c.71
MARIBOR
tel.02/462-20-41
fax.02462-28-41
mob.041-740-663
hoh@siol.net
www.HOH.si

Prodajni program:
MERILNA TEHNIKA-INSTRUMENTI
HIDRAVLIKA & ORODJA & STROJI



BDS Magnet-Kernbohrtechnik: Einfach besser bohren!

Magnet-Kernbohrmaschinen,
Kernbohrer und Zubehör
für die professionelle
Anwendung. BDS-Qualität
made in Germany!



























Alle Leistungsmerkmale der BDS Magnet-Kernbohrmaschinen im direkten Vergleich!

	Leistung
	Schnellwechsel-Bohrsystem KEYLESS  MK 2/MK 3 19 mm Weldon $\frac{3}{4}$ "
	Industrieraufnahme MK 3 32 mm Weldon $1\frac{1}{4}$ "
	Direktaufnahme 19 mm Weldon $\frac{3}{4}$ " 32 mm Weldon $1\frac{1}{4}$ "
	Kernbohrer kurz · 30 mm
	Kernbohrer lang · 55 mm
	Kernbohrer extra lang · 110 mm
	Spiralbohren
	Reiben
	Senken
	Gewindeschneiden
	Getriebestufen
	Hub
	Permanente Innenschmierung
	Rutschkupplung
	v-max
	Vollwellen-Regelelektronik
	Drehmoment-Kontrolle
	Magnetindikator
	Thermoschutz
	Rechts-/Links-Lauf
	Drehvorrichtung 30° beidseitig, 20 mm längs Gewicht

MAB 100

Die ideale Einsteiger-
maschine, kompakt,
handlich und kraftvoll.

	800 Watt
	-
	-
	19 mm ✓
	ø12-30 mm
	-
	-
	-
	-
	-
	-
	450 min ⁻¹
	80 mm
	✓
	-
	-
	-
	-
	-
	-
	9,9 kg
	-























Bestell Nr.

MAB 100/ 230 Volt

MAB 100/ 110 Volt

MAB 150

Mit Winkelgetriebe –
Bohren auf engstem
Raum.

	1080 Watt
	-
	-
	19 mm ✓
	ø12-35 mm
	-
	-
	-
	-
	-
	-
	400 min ⁻¹
	39 mm
	✓
	-
	-
	-
	-
	-
	-
	11 kg
	-

Bestell Nr.

MAB 150/ 230 Volt

MAB 150/ 110 Volt

Mit Ratsche



MAB 150-R/ 230 Volt























MAB 150-R/ 110 Volt



MAB Der BDS-Klassiker – in
425 der Werkstatt einfach
 perfekt.

MAB Die leistungsstarke
455 Montagemaschine.
 KEYLESS serienmäßig.

	1050 Watt
	-
	-
	19 mm ✓
	ø12–35 mm
	-
	-
	ø16
	-
	-
	-
	430 min ⁻¹ 760 min ⁻¹
	160 mm
	✓
	-
	-
	-
	✓
	-
	-
	13 kg
	-
Bestell Nr.	
MAB 425/ 230 Volt	
MAB 425/ 110 Volt	

	1150 Watt
	MK 2
	-
	-
	ø12–40 mm
	ø12–40
	-
	ø18
	-
	-
	-
	250 min ⁻¹ 450 min ⁻¹
	160 mm
	✓
	-
	-
	-
	✓
	-
	-
	13 kg
	-
Bestell Nr.	
MAB 455/ 230 Volt	
MAB 455/ 110 Volt	



MAB 485

Besonders vielseitig
für Werkstatt und
Montage.

	1150 Watt	
	 -  -	
	MK 2	
	ø12-40 mm	
	ø12-40	 -
	ø18	 ø18 mm
	ø40	 M16
	50 - 250 min ⁻¹ 100 - 450 min ⁻¹	
	160 mm	
	✓  -  -	
	✓  ✓	
	✓  ✓	
	13 kg  -	
Bestell Nr.		
MAB 485/ 230 Volt		
MAB 485/ 110 Volt		

MAB 525



Robust und leicht zu-
gleich! Mit 2-stufigem
Ölbadgetriebe, Gewin-
deschneiden bis M20.















	1600 Watt	
	 -  -	
	MK 3	
	ø12-50 mm	
	ø12-50	 -
	ø23	 ø23 mm
	ø50	 M20
	90 - 280 min ⁻¹ 180 - 580 min ⁻¹	
	160 mm	
	✓  -  ✓	
	✓  ✓	
	✓  ✓	
	17 kg  -	
Bestell Nr.		
MAB 525/ 230 Volt		
MAB 525/ 110 Volt		



MAB 825

Entwickelt für den
Stahlbau, Anlagenbau
und für den Maschi-
nenbau.

	1800 Watt		
	 MK 3		
	ø 12–100 mm		
	ø 12–100		ø 20–50 mm
	ø 31,75		ø 31,75 mm
	ø 50		M30

	40 – 110 min ⁻¹ 65 – 175 min ⁻¹
	140 – 370 min ⁻¹ 220 – 600 min ⁻¹
	255 mm
	✓  ✓  ✓
	✓  ✓
	✓  ✓
	 ✓
	25 kg  –

Bestell Nr.















MAB 825/ 230 Volt

MAB 825/ 110 Volt

MAB 845

Zusätzlich mit der
exakt justierbaren
Drehvorrichtung.

	1800 Watt		
	 MK 3		
	ø 12–100 mm		
	ø 12–100		ø 20–50 mm
	ø 31,75		ø 31,75 mm
	ø 50		M30

	40 – 110 min ⁻¹ 65 – 175 min ⁻¹
	140 – 370 min ⁻¹ 220 – 600 min ⁻¹
	255 mm
	✓  ✓  ✓
	✓  ✓
	✓  ✓
	 ✓
	25 kg  ✓

Bestell Nr.

















MAB 845/ 230 Volt

MAB 845/ 110 Volt



MAB 1300























Die stärkste Magnet-Kernbohrmaschine am Markt! Jetzt auch zum Gewindeschneiden geeignet.

	2300 Watt		
	-		
	MK 4		
	19/32 mm		
	ø 12-130 mm		
	ø 12-100		ø 20-120 mm
	ø 45		ø 50
	ø 80		M42
	30 - 80 min ⁻¹ 50 - 120 min ⁻¹ 130 - 350 min ⁻¹ 210 - 550 min ⁻¹		
	85 / 310 mm		
	✓  ✓  ✓		
	✓  ✓		
	✓  ✓		
	51 kg  -		
Bestell Nr.			
MAB 1300/ 230 Volt			
MAB 1300/ 110 Volt			



Air MAB 5000

Die Magnet-Kernbohrmaschine mit Druckluftantrieb.

	Luftverbrauch 0,85 m ³ /min.		
	MK 2		
	-		
	-		
	ø 12-35 mm		
	ø 12-35		-
	ø 23		-
	-		-
	315 min ⁻¹		
	150 mm		
	✓  -  -		
	✓  -		
	-  -		
	17,5 kg  -		
Bestell Nr.			
MAB 5000			



Zubehör

Für BDS Magnet-Kernbohrmaschinen

Vakuumpumpe für Riffel- und Kreuzbleche



Anwendung: Speziell für Riffel- und Kreuzbleche geeignet.
Ausführung: Hochleistungsvakuumpumpe mit Ölumlaufschmierung.
Spannplatte \varnothing 300 mm.
Bestell Nr.
ZAV 300*

Vakuumpumpe für glatte Oberflächen



Anwendung: Für glatte Oberflächen.
Ausführung: Hochleistungsvakuumpumpe mit Ölumlaufschmierung.
Spannplatte mit zwei Saugflächen und innenliegendem Bohrbereich.
Abmessung: 440 x 260 mm
Langloch: 50 x 120 mm
Bestell Nr.
ZAV 400*

Rohrspannvorrichtung

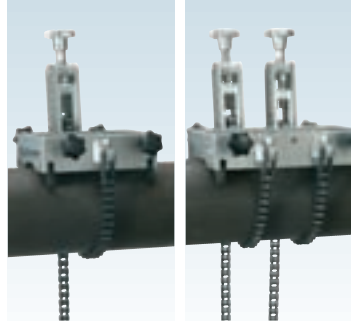

ZRO 250: Für: MAB 425, 455, 485,
Für Rohr \varnothing : 80 – 250 mm
Kettenlänge: 900 mm
ZRO 500: Für: MAB 525, 825, 845,
Für Rohr \varnothing : 150 – 500 mm
Kettenlänge: 1.650 mm
Bestell Nr.
ZRO 250
ZRO 500

*Lieferumfang ohne BDS Magnet-Kernbohrmaschine

BDS StarterKit



Das neue BDS StarterKit ist die optimale Grundausstattung für alle BDS Magnet-Kernbohrmaschinen

- ▶ 1 Standard Kernbohrer Box mit je
2 KBK – \varnothing 14 + 18 mm
1 KBK – \varnothing 22 mm
- ▶ 1 | Hochleistungsschneidöl BDS 5000
- ▶ 1 BDS Power-Worker

Zubehör

Für BDS Magnet-Kernbohrmaschinen

BDS 5000 – Hochleistungsschneidöl



Anwendung: Zur Schmierung von BDS HSS Kernbohrer.

Bestell Nr.	Inhalt
ZHS 005	5 l Kanister
ZHS 006	1 l Dose

Industriebohrständer und Zubehör für Standard-Bohrmaschinen



ø 43 mm

Die Handbohrmaschine ist nicht im Lieferumfang enthalten.

Bestell Nr.	Artikel
ZBS 100	Industriebohrständer
ZST 300	Prismenschraubstock
ZTN 100	Schrauben für T-Nut
ZSM 100	Sechskantmutter mit Bund

Schmier- und Hilfsstoffe



Bestell Nr.	Bezeichnung und Anwendung	Inhalt
ZHS 550	BDS 5500 – Schneidpaste für schwer zerspanbare Materialien	1.000 g
ZSR 100	BDS 1000 – der Sprühreiniger reinigt und entfettet alle Metalle	500 ml
ZHS 400	BDS 5200 – Fettspray für Bohrarbeiten überkopf oder horizontal	1 x 400 ml
ZHS 406	BDS 5200 – Fettspray für Bohrarbeiten überkopf oder horizontal	6 x 400 ml
ZHS 412	BDS 5200 – Fettspray für Bohrarbeiten überkopf oder horizontal	12 x 400 ml
ZHB 001	BDS 6000 – Kühlschmierkonzentrat, auf synthetischer Basis zur Kühlung von BDS Hartmetall Kernbohrer	1000 ml

Zubehör – Gewindeschneiden

Schnellwechselsystem für das flexible Einsetzen und Wechseln der Gewindebohrer.



Gewindeschneid-Schnellwechselfutter
Größe 1, 2, 3
für Gewindebohrer M3, M5, M14

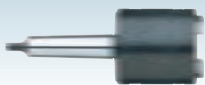

Best. Nr.	Aufnahme	Gewindebohrer
GSW 331	MK 3	M 3 – M 14
GSW 332	MK 3	M 5 – M 24
GSW 333	MK 3	M 14 – M 30

Satz Schnellwechsel-Einsätze für
Gewindeschneid-Schnellwechselfutter
Größe 1, 2, 3

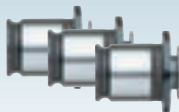

Best. Nr.	Bestückung
GSE 100	M 3 - M 14
GSE 200	M 5 - M 24
GSE 300	M 14 - M 30

Gewindebohren – schnell & preiswert!



Gewindebohreradapter
mit Weldonshaft

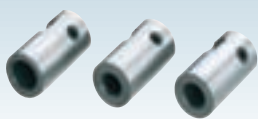

Best. Nr.	Gewinde	Schaftø	Vierkant
ZGA 010	M10 DIN 376	7	5,5
ZGA 012	M12 DIN 376	9	7
ZGA 014	M14 DIN 376	11	9
ZGA 016	M16 DIN 376	12	9
ZGA 018	M18 DIN 376	14	11
ZGA 020	M20 DIN 376	16	12
ZGA 022	M22 DIN 376	18	14,5
ZGA 024	M24 DIN 376	18	14,5
ZGA 027	M27 DIN 376	20	16
ZGA 030	M30 DIN 376	22	18

Schnellwechsel-Einsätze zur Aufnahme
von Gewindebohrern für Gewindeschneid-
Schnellwechselfutter Größe 1, 2, 3



Best. Nr.	Größe	Gewinde	Schaftø	Vierkant
GSE 103	1	M3	3,5	2,7
GSE 104	1	M4	4,5	3,4
GSE 105	1	M5/M6	6	4,9
GSE 108	1	M8	8	6,3
GSE 110	1	M10	10	8
GSE 112	1	M12	9	7,1
GSE 114	1	M14	11	7
GSE 205	2	M5/M6	4,9	
GSE 208	2	M8	6	4,9
GSE 210	2	M10	10	8
GSE 212	2	M12	9	7,1
GSE 214	2	M14	11	7
GSE 216	2	M16	12	9
GSE 218	2	M18	14	11
GSE 220	2	M20	16	12
GSE 222	2	M22	18	14,5
GSE 314	3	M14	11	9
GSE 316	3	M16	12	9
GSE 318	3	M18	14	11
GSE 320	3	M20	16	12
GSE 322	3	M22/M24	18	14,5
GSE 327	3	M27	20	16
GSE 330	3	M30	22	18

Gewindeschneid-Schnellwechselfutter GSW und Schnellwechsel-Einsätze GSS mit Rutschkupplung siehe BDS Gesamtkatalog!



Serie VarioPLUS

HSS Vollschliff-Kernbohrer mit Hartstoffbeschichtung.

Kurze und lange Ausführung, metrisch. Schnitttiefe 30 und 55 mm.

KBK Box VarioPLUS



Bestell Nr.

KBK BOX1-V

2 x KBK-VP 014

2 x KBK-VP 018

1 x KBK-VP 022

Schnitttiefe 30 mm

KBL Box VarioPLUS



Bestell Nr.

KBL BOX VARIO PLUS

2 x KBL-VP 014

2 x KBL-VP 018

1 x KBL-VP 022

Schnitttiefe 30 mm

KBK-VarioPLUS/30 mm · KBL-VarioPLUS/55 mm

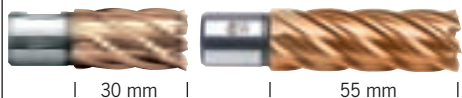

Bestell Nr.		Bestell Nr.	
30 mm / ø	55 mm / ø	30 mm / ø	55 mm / ø
KBK-VP 012	KBL-VP 012	KBK-VP 039	KBL-VP 039
KBK-VP 013	KBL-VP 013	KBK-VP 040	KBL-VP 040
KBK-VP 014	KBL-VP 014	KBK-VP 041	KBL-VP 041
KBK-VP 015	KBL-VP 015	KBK-VP 042	KBL-VP 042
KBK-VP 016	KBL-VP 016	KBK-VP 043	KBL-VP 043
KBK-VP 017	KBL-VP 017	KBK-VP 044	KBL-VP 044
KBK-VP 17.5	KBL-VP 17.5	KBK-VP 045	KBL-VP 045
KBK-VP 018	KBL-VP 018	KBK-VP 046	KBL-VP 046
KBK-VP 019	KBL-VP 019	KBK-VP 047	KBL-VP 047
KBK-VP 19.5	KBL-VP 19.5	KBK-VP 048	KBL-VP 048
KBK-VP 020	KBL-VP 020	KBK-VP 049	KBL-VP 049
KBK-VP 021	KBL-VP 021	KBK-VP 050	KBL-VP 050
KBK-VP 022	KBL-VP 022	KBK-VP 051	KBL-VP 051
KBK-VP 023	KBL-VP 023	KBK-VP 052	KBL-VP 052
KBK-VP 024	KBL-VP 024	KBK-VP 053	KBL-VP 053
KBK-VP 025	KBL-VP 025	KBK-VP 054	KBL-VP 054
KBK-VP 026	KBL-VP 026	KBK-VP 055	KBL-VP 055
KBK-VP 027	KBL-VP 027	KBK-VP 056	KBL-VP 056
KBK-VP 028	KBL-VP 028	KBK-VP 057	KBL-VP 057
KBK-VP 029	KBL-VP 029	KBK-VP 058	KBL-VP 058
KBK-VP 030	KBL-VP 030	KBK-VP 059	KBL-VP 059
KBK-VP 031	KBL-VP 031	KBK-VP 060	KBL-VP 060
KBK-VP 032	KBL-VP 032		
KBK-VP 033	KBL-VP 033		
KBK-VP 034	KBL-VP 034		
KBK-VP 035	KBL-VP 035		
KBK-VP 036	KBL-VP 036		
KBK-VP 037	KBL-VP 037		
KBK-VP 038	KBL-VP 038		

Auswerferstifte



Bestell Nr.

ZAK 075 für KBK-VP

ZAK 100 für KBL-VP

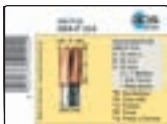

Serie Hartmetall

Hartmetall-Kernbohrer und Hartmetall-Kernbohrer mit Hartstoffbeschichtung.
Kurze Ausführung, metrisch.
Schnitttiefe 35 mm.

HKK Box



Bestell Nr.

HKK BOX

2 x HKK 014

2 x HKK 018

1 x HKK 022

Schnitttiefe 35 mm

HKK Box PLUS



Bestell Nr.

HKK BOX PLUS

2 x HKK-P 014

2 x HKK-P 018

1 x HKK-P 022

Schnitttiefe 35 mm



One-Touch Rota-Quick

WELDON
19 mm ³/₄"

HKK

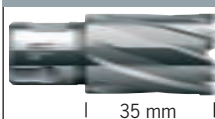

35 mm

Bestell Nr.

HKK / ø HKK-P / ø

HKK 014 HKK-P 014

HKK 015 HKK-P 015

HKK 016 HKK-P 016

HKK 017 HKK-P 017

HKK 018 HKK-P 018

HKK 019 HKK-P 019

HKK 020 HKK-P 020

HKK 021 HKK-P 021

HKK 022 HKK-P 022

HKK 023 HKK-P 023

HKK 024 HKK-P 024

HKK 025 HKK-P 025

HKK 026 HKK-P 026

HKK 027 HKK-P 027

HKK 028 HKK-P 028

HKK 029 HKK-P 029

HKK 030 HKK-P 030

HKK 031 HKK-P 031

HKK 032 HKK-P 032

HKK 033 HKK-P 033

HKK 034 HKK-P 034

HKK 035 HKK-P 035

HKK 036 HKK-P 036

HKK 037 HKK-P 037

HKK 038 HKK-P 038

HKK 039 HKK-P 039

HKK 040 HKK-P 040

HKK 041 HKK-P 041

HKK 042 HKK-P 042

HKK-P

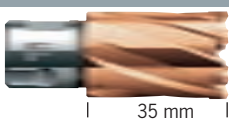

35 mm

Bestell Nr.

HKK / ø HKK-P / ø

HKK 043 HKK-P 043

HKK 044 HKK-P 044

HKK 045 HKK-P 045

HKK 046 HKK-P 046

HKK 047 HKK-P 047

HKK 048 HKK-P 048

HKK 049 HKK-P 049

HKK 050 HKK-P 050

HKK 051 HKK-P 051

HKK 052 HKK-P 052

HKK 053 HKK-P 053

HKK 054 HKK-P 054

HKK 055 HKK-P 055

HKK 056 HKK-P 056

HKK 057 HKK-P 057

HKK 058 HKK-P 058

HKK 059 HKK-P 059

HKK 060 HKK-P 060

Auswerferstifte



Bestell Nr.

≤ HKK/HKK-P ø 17 mm

ZAK 096

≥ HKK/HKK-P ø 18 mm

ZAK 090

Weiter Größen/Ausführungen siehe BDS Gesamtkatalog!



Serie Standard

HSS Vollschliff-Kernbohrer.

Kurze und lange Ausführung, metrisch.
Schnitttiefe 30 und 55 mm.



KBK Box Standard



Bestell Nr.

KBK BOX1

2 x KBK 014

2 x KBK 018

1 x KBK 022

Schnitttiefe 30 mm

KBL Box Standard



Bestell Nr.

KBL BOX1

2 x KBL 014

2 x KBL 018

1 x KBL 022

Schnitttiefe 55 mm

KBK Standard/30 mm · KBL Standard/55 mm

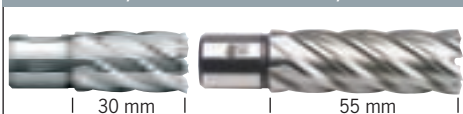

Bestell Nr.		Bestell Nr.	
30 mm / ø	55 mm / ø	30 mm / ø	55 mm / ø
KBK 012	KBL 012	KBK 039	KBL 039
KBK 013	KBL 013	KBK 040	KBL 040
KBK 014	KBL 014	KBK 041	KBL 041
KBK 015	KBL 015	KBK 042	KBL 042
KBK 016	KBL 016	KBK 043	KBL 043
KBK 017	KBL 017	KBK 044	KBL 044
KBK 17.5	KBL 17.5	KBK 045	KBL 045
KBK 018	KBL 018	KBK 046	KBL 046
KBK 019	KBL 019	KBK 047	KBL 047
KBK 19.5	KBL 19.5	KBK 048	KBL 048
KBK 020	KBL 020	KBK 049	KBL 049
KBK 021	KBL 021	KBK 050	KBL 050
KBK 022	KBL 022	KBK 051	KBL 051
KBK 023	KBL 023	KBK 052	KBL 052
KBK 024	KBL 024	KBK 053	KBL 053
KBK 025	KBL 025	KBK 054	KBL 054
KBK 026	KBL 026	KBK 055	KBL 055
KBK 027	KBL 027	KBK 056	KBL 056
KBK 028	KBL 028	KBK 057	KBL 057
KBK 029	KBL 029	KBK 058	KBL 058
KBK 030	KBL 030	KBK 059	KBL 059
KBK 031	KBL 031	KBK 060	KBL 060
KBK 032	KBL 032		
KBK 033	KBL 033		
KBK 034	KBL 034		
KBK 035	KBL 035		
KBK 036	KBL 036		
KBK 037	KBL 037		
KBK 038	KBL 038		

Auswerferstifte



Bestell Nr.

ZAK 075 für KBK

ZAK 100 für KBL